

# TB 9-6625-2332-50

CHANGE 2

DEPARTMENT OF THE ARMY TECHNICAL BULLETIN

---

## CALIBRATION PROCEDURE FOR PULSE GENERATOR (LECROY, MODEL 9210 MOD 200)

---

Headquarters, Department of the Army, Washington, DC  
15 July 2005

---

*Distribution Statement A: Approved for public release; distribution is unlimited.*

---

TB 9-6625-2332-50, 7 October 2002, is changed as follows:

1. Remove old pages and insert new pages as indicated below. New or changed material is indicated by a vertical bar in the margin of the page.

**Remove Pages**  
19 and 20

**Insert Pages**  
19 and 20

2. File this change sheet in front of the publication for reference purposes.

By Order of the Secretary of the Army:

Official:



SANDRA R. RILEY  
*Administrative Assistant to the  
Secretary of the Army*

0514405

PETER J. SCHOOMAKER  
*General, United States Army  
Chief of Staff*

Distribution:

To be distributed in accordance with IDN 344748, requirements for calibration procedure  
TB 9-6625-2332-50.

# TB 9-6625-2332-50

CHANGE 1

DEPARTMENT OF THE ARMY TECHNICAL BULLETIN

---

## CALIBRATION PROCEDURE FOR PULSE GENERATOR (LECROY, MODEL 9210 MOD 200)

---

Headquarters, Department of the Army, Washington, DC  
29 March 2005

---

*Distribution Statement A: Approved for public release; distribution is unlimited.*

---

TB 9-6625-2332-50, 7 October 2002, is changed as follows:

1. Remove old pages and insert new pages as indicated below. New or changed material is indicated by a vertical bar in the margin of the page.

**Remove Pages**

3 thru 6  
19 thru 24

**Insert Pages**

3 thru 6  
19 thru 24

2. File this change sheet in front of the publication for reference purposes.

By Order of the Secretary of the Army:

Official:



SANDRA R. RILEY  
*Administrative Assistant to the  
Secretary of the Army*

0503117

PETER J. SCHOOMAKER  
*General, United States Army  
Chief of Staff*

Distribution:

To be distributed in accordance with IDN 344748, requirements for calibration procedure  
TB 9-6625-2332-50.

# TB 9-6625-2332-50

DEPARTMENT OF THE ARMY TECHNICAL BULLETIN

## CALIBRATION PROCEDURE FOR PULSE GENERATOR (LECROY, MODEL 9210 MOD 200)

Headquarters, Department of the Army, Washington, DC

7 October 2002

*Approved for public release; distribution is unlimited distribution is unlimited.*

### REPORTING OF ERRORS AND RECOMMENDING IMPROVEMENTS

You can improve this manual. If you find any mistakes or if you know of a way to improve these procedures, please let us know. Mail your letter, DA Form 2028 (Recommended Changes to Publications and Blank Forms) directly to Commander, U.S. Army Aviation and Missile Command, ATTN: AMSAM-MMC-MA-NP, Redstone Arsenal, AL 35898-5000. A reply will be furnished to you. You may also provide DA Form 2028 information to AMCOM via e-mail, fax, or the World Wide Web. Our FAX number is: DSN 788-6546 or Commercial 256-842-6546.

Our e-mail address is: [2028@redstone.army.mil](mailto:2028@redstone.army.mil). Instructions for sending an electronic 2028 may be found at the back of this publication. For the World Wide Web, use:

<https://amcom2028.redstone.army.mil>.

SECTION		Paragraph	Page
I.	IDENTIFICATION AND DESCRIPTION		
	Test instrument identification .....	1	2
	Forms, records, and reports .....	2	2
	Calibration description .....	3	2
II.	EQUIPMENT REQUIREMENTS		
	Equipment required .....	4	3
	Accessories required .....	5	3
III.	CALIBRATION PROCESS		
	Preliminary instructions .....	6	4
	Equipment setup .....	7	4
	Output amplitude .....	8	5
	Period .....	9	10
	Risetime/falltime .....	10	12
	Pulse width .....	11	14
	Pulse jitter .....	12	16
	Delay .....	13	17
	Trigger level and polarity .....	14	20
	Double Pulse .....	15	23
	Final procedure .....	16	24

**SECTION I  
IDENTIFICATION AND DESCRIPTION**

**1. Test Instrument Identification.** This bulletin provides instructions for the calibration of Pulse Generator, (LeCroy, Model 9210 Mod 200). The manufacturer's manual was used as the prime data source in compiling these instructions. The equipment being calibrated will be referred to as the TI (test instrument) throughout this bulletin.

**a. Model Variations.** None.

**b. Time and Technique.** The time required for this calibration is approximately 6 hours, using the dc and low frequency and microwave technique.

**2. Forms, Records, and Reports.** Forms, records, and reports required for calibration personnel at all levels are prescribed by TB 750-25.

**3. Calibration Description.** TI parameters and performance specifications which pertain to this calibration are listed in table 1.

Table 1. Calibration Description

Test instrument parameters	Performance specifications
9210 Main Frame	
Period accuracy	Range: 1 nsec to 500 msec Accuracy: $\pm 0.5\%$ of programmed value + 0.2 nsec
Pulse width accuracy	Range: 1 nsec to 500 msec Accuracy: $\pm 0.5\%$ of programmed value + 0 nsec
Pulse delay accuracy	Range: 0 nsec to 500 msec Accuracy: $\pm 0.5\%$ of programmed value + 1 nsec
RMS jitter	$\leq 0.035\%$ of programmed value + 5 psec
External trigger	Accuracy: $\pm 100$ mV Trigger Slope: Positive or negative Double Pulse: When double pulse is set to on, two pulses are produced for each trigger pulse.
9211 Module	
Amplitude	Range: $\pm 5$ V Accuracy: $\pm 1\%$ of programmed value + $1\%$ of amplitude + 40 mV into $50\Omega$
Variable risetime/falltime	10% to 90% point Accuracy: $\pm 10\%$ of programmed value + 300 psec
9215 Module	
Amplitude	Range: $\pm 15$ V Accuracy: $\pm 1\%$ of programmed value + $1\%$ of amplitude + 5 mV into $50\Omega$
Variable risetime/falltime	Range: 10% to 90% point Accuracy: $\pm 20\%$ of programmed value + 300 psec

## SECTION II EQUIPMENT REQUIREMENTS

**4. Equipment Required.** Table 2 identifies the specific equipment to be used in this calibration procedure. This equipment is issued with Secondary Reference Standards Set, NSN 4931-00-621-7878. Alternate items may be used by the calibrating activity. The items selected must be verified to perform satisfactorily prior to use and must bear evidence of current calibration. The equipment must meet or exceed the minimum use specifications listed in table 2. The accuracies listed in table 2 provided a four-to-one ratio between the standard and TI. Where the four-to-one ratio cannot be met, the actual accuracy of the equipment is shown in parenthesis.

**5. Accessories Required.** The accessories required for the calibration are common usage accessories, issued as indicated in paragraph 4 above, and are not listed in this calibration procedure.

Table 2. Minimum Specifications of Equipment Required

Common name	Minimum use specifications	Manufacturer and model (part number)
ATTENUATOR (20 dB)	50 $\Omega$ 2 Watt (2 required)	Tektronix Model 011-0059-02 (011-0059-02)
DIGITIZING OSCILLOSCOPE	Risetime/falltime measurement: Accuracy: <100 psec Period: Accuracy: $\pm 62.5$ psec Pulse Width: Accuracy: $\pm 77.5$ psec RMS Jitter: Accuracy: <15 psec	Hewlett-Packard, Model 54121T (54121T)
FUNCTION/ARBITRARY GENERATOR	Range: 1 .02 Vpp Accuracy: $\pm 20$ mV Range: 1.5 MHz Accuracy: $\pm 1$ Hz	Agilent, Model 33250A (33250A)
MULTIMETER	Range: 15 to -15 V dc Accuracy: $\pm .25\%$ Range: 20 k $\Omega$ Accuracy: $\pm 2.5\%$	Fluke, Model 8840A/AF-05 (AN/GSM-64D)
OSCILLOSCOPE	Range: 1 V per division Accuracy: $\pm 3\%$ Range: 100 nsec per division Accuracy: $\pm 1\%$	(OS-303/G)
TERMINATOR	50 $\Omega$ 20 Watt	NARDA Model 374NM (374NM)

### SECTION III CALIBRATION PROCESS

#### 6. Preliminary Instructions

a. The instructions outlined in paragraphs 6 and 7 are preparatory to the calibration process. Personnel should become familiar with the entire bulletin before beginning the calibration.

b. Items of equipment used in this procedure are referenced within the text by common name as listed in table 2.

c. Unless otherwise specified, verify the result of each test and, whenever the test requirement is not met, take corrective action before continuing with the calibration. Adjustments required to calibrate the TI are included in this procedure.

d. Unless otherwise specified, all controls and control settings refer to the TI.

#### 7. Equipment Setup

##### WARNING

HIGH VOLTAGE is used or exposed during the performance of this calibration. DEATH ON CONTACT may result if personnel fail to observe safety precautions. REDUCE OUTPUT(S) to minimum after each step within the performance check where applicable.

##### NOTE

Before connecting TI, the protective earth terminal of the instrument must be connected to the protective conductor of the line power cord. The line plug shall only be inserted in a socket outlet provided with a protective earth contact. The protective action must not be negated by the use of an extension cord (power cable) without a protective conductor (grounding). Grounding one conductor of a two-conductor outlet is not sufficient protection.

**NOTE**

When indications specified in this procedure are not within tolerance, perform the power supply check prior to making adjustments.

- a. Configure TI as shown in figure 1.

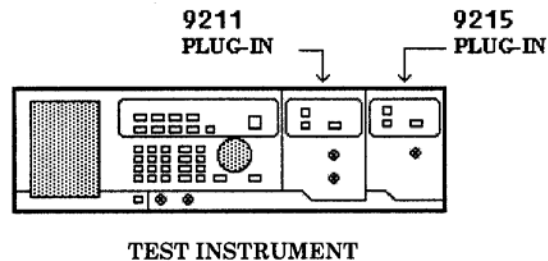

Figure 1. Test instrument configuration.

- b. Connect TI to a 115 V ac power source.
- c. Press **POWER** key to on and allow at least 15 minutes for TI to stabilize.

## 8. Output Amplitude

### a. Performance Check

- (1) On TI press **RECALL SETUP** pushbutton and select **STANDARD** key on the crt.
- (2) Press TI keys as indicated in (a) thru (c) below.
  - (a) **MORE.**
  - (b) **CAL.**
  - (c) **EXECUTE.**
- (3) Wait for TI to finish self calibration.
- (4) Press TI keys as indicated in (a) thru (c) below.
  - (a) **MORE.**
  - (b) **SELF TEST.**
  - (c) **EXECUTE.**
- (5) Wait for TI to finish self test.
- (6) Connect equipment as shown in figure 2 below.

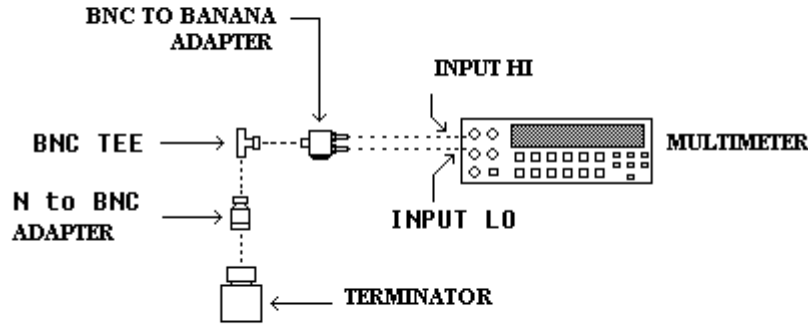

Figure 2. Termination check.

(7) Setup multimeter to measure ohms.

(8) Using multimeter, measure ohms. Multimeter indication will be within the limits specified in table 3. Record the measured value as actual termination resistance in ohms.

Table 3. Termination Check

Multimeter indication ( $\Omega$ )	
Min	Max
45	55

(9) Calculate the termination correction factor using the formula below:

$$[.5] / [ \text{actual termination resistance} / ( \text{actual termination resistance} + 50 ) ]$$

example

$$[.5] / [ 49 / ( 49 + 50 ) ]$$

$$[.5] / [ 49 / ( 99 ) ]$$

$$[.5] / [.4949] = 1.01 = \text{Termination correction factor}$$

(10) Record the termination correction factor in table 4, 5, 6, and 7.

(11) Setup multimeter to measure V dc.



(12) Connect TI 9211 module **OUTPUT** (upper BNC connector) to the open end of the BNC tee adapter on the front of the multimeter.

(13) Press TI pushbuttons as listed in (a) through (f) below:

- (a) **CHANNEL A.**
- (b) **Vhigh** and enter **5** from data keyboard and press **ENTER/HZ.**
- (c) **Vlow** and enter **0** from data keyboard and press **ENTER/HZ.**
- (d) **Trigger-Mode** and repeatedly press **ENTER/HZ** until **EXT. WIDE** mode is selected.
- (e) **Trigger slope (-).**
- (f) **DISABLE** (model 9211 output module) to on (red light extinguished).

(14) Record multimeter indication in table 4 under actual multimeter reading for **Vhigh** setting.

(15) Multiply the actual multimeter reading, times the termination correction factor, and record the results in table 4.

(16) Verify that the value recorded in (15) above is within limits specified for the **Vhigh** setting in table 4.

(17) Set TI to the next **Vhigh** setting listed in table 4 and repeat (14) through (16) above.

(18) Repeat (17) above for the remaining **Vhigh** settings listed in table 4.

Table 4. 9211 Positive Output Amplitude

Test instrument <b>Vhigh</b> setting	Multimeter indication	Termination correction factor	Min	Multimeter indication X termination correction factor	Max
5.0			4.86		5.14
3.0			2.9		3.1
1.0			.94		1.06
0.5			0.45		0.55
0.3			0.254		0.346
0.1			0.058		0.142

(19) Press TI pushbuttons as listed in (a) through (c) below:

- (a) **Vhigh** and enter **0** from data keyboard and press **ENTER/HZ.**
- (b) **Vlow** and enter **-5** from data keyboard and press **ENTER/HZ.**
- (c) **TRIGGER SLOPE POSITIVE.**

(20) Record multimeter indication in table 5 under actual multimeter reading for **Vlow** setting.

(21) Multiply the actual multimeter reading times the termination correction factor and record the results in table 5.

(22) Verify that the value recorded in (21) above is within limits specified for the **Vlow** setting.

(23) Set TI to the next **Vlow** setting listed in table 5 and repeat (20) through (22) above.

(24) Repeat (23) above for the remaining **Vlow** settings listed in table 5.

Table 5. 9211 negative Output Amplitude

Test instrument <b>Vlow</b> setting	Multimeter indication	Termination correction factor	Min	Multimeter indication X termination correction factor	Max
-5.0			-5.14		-4.86
-3.0			-3.1		-2.9
-1.0			-1.06		-0.94
-0.5			-0.55		-0.45
-0.3			-0.346		0.254
-0.1			-0.142		0.058

(25) Press **DISABLE** pushbutton (model 9211 output module) to off ( red light lit).

(26) Disconnect TI 9211 module **OUTPUT** from BNC tee adapter.

(27) Connect TI 9215 module **OUTPUT** to the open end of the BNC tee adapter on the front of the multimeter.

(28) Press TI pushbuttons as listed in (a) through (f) below:

- (a) **CHANNEL B.**
- (b) **Vhigh** and enter **15** from data keyboard and press **ENTER/HZ.**
- (c) **Vlow** and enter **0** from data keyboard and press **ENTER/HZ.**
- (d) **Trigger Mode Ext. Wid.**
- (e) **Trigger slope (-).**
- (f) **DISABLE** (9215 output module) to on (red light extinguished).

(29) Record multimeter indication in table 6 under actual multimeter reading for **Vhigh** setting.

(30) Multiply the actual multimeter reading times the termination correction factor and record the results in table 6.

(31) Verify that the value recorded in (30) above is within limits specified for the **Vhigh** setting.

(32) Set TI to the next **Vhigh** setting listed in table 6 and repeat (29) through (31) above.

(33) Repeat (32) above for the remaining **Vhigh** settings listed in table 6.

Table 6. 9215 Positive Output Amplitude

Test instrument <b>Vhigh</b> setting	Multimeter indication	Termination correction factor	Min	Multimeter indication X termination correction factor	Max
15.0			14.845		15.155
10.0			9.895		10.105
5.0			4.945		5.055

(34) Press TI pushbuttons as listed in (a) through (c) below:

- (a) **Vhigh** and enter **0** from data keyboard and press **ENTER/HZ**.
- (b) **Vlow** and enter **-5** from data keyboard and press **ENTER/HZ**.
- (c) **TRIGGER SLOPE POSITIVE**.

(35) Record multimeter indication in table 7 under actual multimeter reading for **Vlow** setting.

(36) Multiply the actual multimeter reading times the termination correction factor and record the results in table 7.

(37) Verify that the value recorded in (36) above is within limits specified for the **Vlow** setting.

(38) Set TI to the next **Vlow** setting listed in table 7 and repeat (35) through (37) above.

(39) Repeat (38) above for the remaining **Vlow** settings listed in table 7.

Table 7. 9215 Negative Output Amplitude

Test instrument <b>Vlow</b> setting	Multimeter indication	Termination correction factor	Min	Multimeter indication X termination correction factor	Max
-5.0			-5.055		-4.945
-10.0			-10.105		-9.895
-15.0			-15.155		-14.845

(40) Press **DISABLE** pushbutton (9215 output module) to off ( red light lit).

(41) Disconnect TI 9215 module **OUTPUT** from BNC tee adapter.

**b. Adjustments.** No adjustments can be made.

9. Period

a. Performance Check

- (1) Connect equipment as shown in figure 3 below.

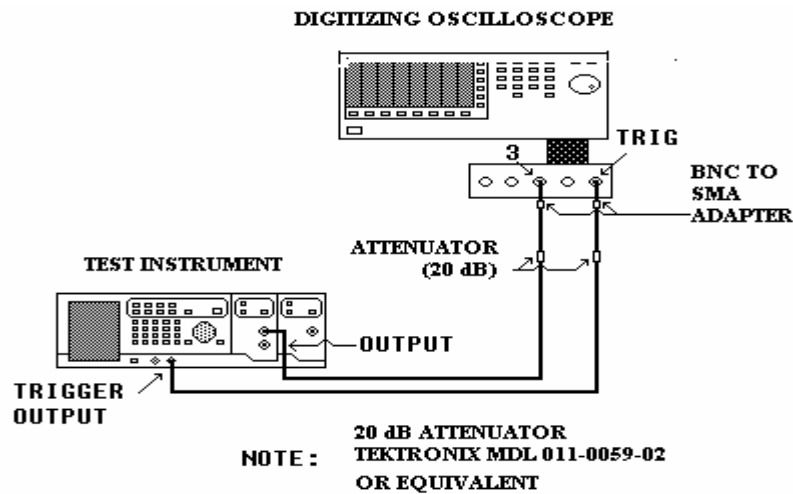

Figure 3. Period.

- (2) Reset digitizing oscilloscope and cal the vertical gain.
- (3) Press TI pushbuttons as listed in (a) through (j) below:
- (a) **CHANNEL A .**
  - (b) **Vhigh** and enter **2.5** from data keyboard and press **ENTER/HZ.**
  - (c) **Vlow** and enter **0** from the data keyboard and press **ENTER/HZ.**
  - (d) **Lead** and enter **.9** from data keyboard and press **n/GHz.**
  - (e) **Trail** and enter **.9** from data keyboard and press **n/GHz.**
  - (f) **Per** and enter **10** from data keyboard and press **n/GHz.**
  - (g) Press **PULSE WIDTH.**
  - (h) Press **CHANGE FORMAT** to **DUTY.**
  - (i) Enter **50** from data keyboard and press **ENTER/HZ.**
  - (j) **DISABLE** (model 9211 output module), to on (red light extinguished).
- (4) Set digitizing oscilloscope channel 3 and trigger probe attenuation to 10.
- (5) Setup digitizing oscilloscope to measure period.
- (6) Verify that the digitizing oscilloscope indicates within the limits listed in table 8 for the **Per** setting.
- (7) Set TI to the next **Per** listed in table 8.
- (8) Repeat (5) and (6) above for the remaining **Per** settings listed in table 8.

Table 8. 9211 Period

Test instrument <b>DATA ENTRY</b> <b>Per</b>	Digitizing oscilloscope indications				
	Min		Max		
10 nsec	9.75	nsec	10.25	nsec	
100 nsec	99.3	nsec	100.7	nsec	
1 μsec	.9948	μsec	1.005	μsec	
10 μsec	9.95	μsec	10.05	μsec	
100 μsec	99.5	μsec	100.5	μsec	
1 msec	.995	msec	1.005	msec	
10 msec	9.95	msec	10.05	msec	
100 msec	99.5	msec	100.5	msec	
500 msec	497.5	msec	502.5	msec	

- (8) Press **DISABLE** pushbutton (model 9211 output module) to off ( red light lit).
- (9) Disconnect cable from TI 9211 module **OUTPUT**.
- (10) Connect cable to TI 9215 module **OUTPUT**.
- (11) Press TI pushbuttons as listed in (a) through (j) below:
  - (a) **CHANNEL B**.
  - (b) **Vhigh** and enter **5** from data keyboard and press **ENTER/HZ**.
  - (c) **Vlow** and enter **0** from the data keyboard and press **ENTER/HZ**.
  - (d) **Lead** and enter **5** from data keyboard and press **n/GHz**.
  - (e) **Trail** and enter **5** from data keyboard and press **n/GHz**.
  - (f) **Per** and enter **20** from data keyboard and press **n/GHz**
  - (g) Press **PULSE WIDTH**.
  - (h) Press **CHANGE FORMAT** to **DUTY**.
  - (i) Enter **50** from data keyboard and press **ENTER/HZ**.
  - (j) **DISABLE** (model 9215 output module) to on (red light extinguished).
- (12) Set digitizing oscilloscope channel 3 and trigger probe attenuation to 10.
- (13) Setup digitizing oscilloscope to measure period.
- (14) Verify that the digitizing oscilloscope indicates within the limits listed in table 9 for the **Per** setting.
- (15) Set TI to the next **Per** listed in table 9.
- (16) Repeat (13) and (14) above for the remaining **Per** settings listed in table 9.

Table 9. 9215 Period

Test instrument <b>DATA ENTRY</b> <b>Per</b>	Digitizing oscilloscope indications				
	Min		Max		
20 nsec	19.7	nsec	20.3	nsec	
100 nsec	99.3	nsec	100.7	nsec	
1 μsec	.9948	μsec	1.005	μsec	

Table 9. 9215 Period - Continued

Test instrument <b>DATA ENTRY</b> <b>Per</b>	Digitizing oscilloscope indications				
	Min			Max	
10     μsec	9.95	nsec	10.05	μsec	
100   μsec	99.5	nsec	100.5	μsec	
1     msec	.995	msec	1.005	msec	
10    msec	9.95	msec	10.05	msec	
100   msec	99.5	msec	100.5	msec	
500   msec	497.5	msec	502.5	msec	

(17) Press **DISABLE** pushbutton (9215 output module) to off ( red light lit).

(18) Disconnect cable from TI 9215 module **OUTPUT**.

**b. Adjustments.** No adjustments can be made.

**10. Risetime/Falltime**

**a. Performance Check**

- (1) Connect equipment as shown in figure 3.
- (2) Reset digitizing oscilloscope and cal the gain.
- (3) Press TI pushbuttons as listed in (a) through (h) below:
  - (a) **CHANNEL A** .
  - (b) **Vhigh** and enter **5** from data keyboard and press **ENTER/HZ**.
  - (c) **Vlow** and enter **0** from the data keyboard and press **ENTER/HZ**.
  - (d) **Lead** and enter **1** from data keyboard and press **n/GHz**.
  - (e) **Trail** and enter **1** from data keyboard and press **n/GHz**.
  - (f) **Per** and enter **1** from data keyboard and press **μ/MHz**.
  - (g) **Duty** and enter **50** from data keyboard and press **ENTER/HZ**.
  - (h) **DISABLE** (model 9211 output module) to on (red light extinguished).

(4) Set digitizing oscilloscope channel 3 and trigger probe attenuation to 10.

(5) Setup digitizing oscilloscope to measure risetime.

(6) Verify that the digitizing oscilloscope indicates within the limits listed in table 10 for the **Lead** setting.

(7) Setup digitizing oscilloscope to measure falltime.

(8) Verify that the digitizing oscilloscope indicates within the limits listed in table 10 for the **Trail** setting.

(9) Set TI to the next **Lead**, **Trail**, and **Per** (if listed) settings listed in table 10.

(10) Repeat (5) through (8) above.

(11) Repeat (9) through (10) above for the remaining **Lead**, **Trail**, and **Per** settings listed in table 10.

Table 10. 9211 Risetime and Falltime

Test instrument settings			Digitizing oscilloscope indications (sec)			
			Risetime		Falltime	
Per setting	Lead setting	Trail setting	Min	Max	Min	Max
1 $\mu$ sec	1e-9	1e-9	0.6e-9	1.4e-9	0.6e-9	1.4e-9
	10e-9	10e-9	8.7e-9	11.3e-9	8.7e-9	11.3e-9
	20e-9	20e-9	17.7e-9	22.3e-9	17.7e-9	22.3e-9
	100e-9	100e-9	90e-9	110e-9	90e-9	110e-9
100 $\mu$ sec	1e-6	1e-6	0.9e-6	1.1e-6	0.9e-6	1.1e-6
	10e-6	10e-6	9e-6	11e-6	9e-6	11e-6
10 msec	100e-6	100e-6	90e-6	110e-6	90e-6	110e-6
	1e-3	1e-3	0.9e-3	1.1e-3	0.9e-3	1.1e-3
200 msec	10e-3	10e-3	9e-3	11e-3	9e-3	11e-3

- (12) Press **DISABLE** pushbutton (model 9211 output module) to off (red light lit).
- (13) Disconnect cable from TI 9211 module **OUTPUT**.
- (14) Connect cable to TI 9215 module **OUTPUT**.
- (15) Set digitizing oscilloscope channel 3 and trigger probe attenuation to 10.
- (16) Press TI pushbuttons as listed in (a) through (h) below:
  - (a) **CHANNEL B**
  - (b) **Vhigh** and enter **5** from data keyboard and press **ENTER/HZ**.
  - (c) **Vlow** and enter **0** from the data keyboard and press **ENTER/HZ**.
  - (d) **Lead** and enter **6.5** from data keyboard and press **n/GHz**.
  - (e) **Trail** and enter **6.5** from data keyboard and press **n/GHz**.
  - (f) **Per** and enter **1** from data keyboard and press  **$\mu$ /MHz**.
  - (g) **Duty** and enter **50** from data keyboard and press **ENTER/HZ**.
  - (h) Press **DISABLE** pushbutton (9215 output module) to on (red light extinguished).
- (17) Setup digitizing oscilloscope to measure risetime.
- (18) Verify that the digitizing oscilloscope indicates within the limits listed in table 11 for the **Lead** setting.
- (19) Setup digitizing oscilloscope to measure falltime.
- (20) Verify that the digitizing oscilloscope indicates within the limits listed in table 11 for the **Trail** setting.
- (21) Set TI to the next **Lead**, **Trail**, and **Per** (if listed) settings listed in table 11.
- (22) Repeat (17) through (20) above.
- (23) Repeat (21) through (22) above for the remaining **Lead**, **Trail**, and **Per** settings listed in table 11.

Table 11. 9215 Risetime and Falltime

Test instrument settings			Digitizing oscilloscope indications (sec)			
Per setting	Lead setting	Trail setting	Risetime		Falltime	
			Min	Max	Min	Max
1 $\mu$ sec	6.5e-9	6.5e-9	4.9e-9	8.1e-9	4.9e-9	8.1e-9
	10e-9	10e-9	7.7e-9	12.3e-9	7.7e-9	12.3e-9
	20e-9	20e-9	15.7e-9	24.3e-9	15.7e-9	24.3e-9
	100e-9	100e-9	79.7e-9	120.3e-9	79.7e-9	120.3e-9
100 $\mu$ sec	1e-6	1e-6	0.799e-6	1.2e-6	0.799e-6	1.2e-6
	10e-6	10e-6	8e-6	12e-6	8e-6	12e-6
10 msec	100e-6	100e-6	80e-6	120e-6	80e-6	120e-6
	1e-3	1e-3	0.8e-3	1.2e-3	0.8e-3	1.2e-3
200 msec	10e-3	10e-3	8e-3	12e-3	8e-3	12e-3
500 msec	100e-3	100e-3	76e-3	114e-3	76e-3	114e-3

(24) Press **DISABLE** pushbutton (model 9215 output module) to off ( red light lit).

(25) Disconnect cable from TI 9215 module **OUTPUT**.

**b. Adjustments.** No adjustments can be made.

## 11. Pulse Width

### a. Performance Check

- (1) Connect equipment as shown in figure 3.
- (2) Reset digitizing oscilloscope and cal the gain.
- (3) Press TI pushbuttons as listed in (a) through (h) below:
  - (a) **CHANNEL A**.
  - (b) **Vhigh** and enter **2.5** from data keyboard and press **ENTER/HZ**.
  - (c) **Vlow** and enter **0** from the data keyboard and press **ENTER/HZ**.
  - (d) **Lead** and enter **.9** from data keyboard and press **n/GHz**.
  - (e) **Trail** and enter **.9** from data keyboard and press **n/GHz**.
  - (f) **Per** and enter **10** from data keyboard and press **n/GHz**.
  - (g) **Wid** and enter **1.6** from data keyboard and press **n/GHz**.
  - (h) Press **DISABLE** pushbutton (model 9211 output module) to on (red light extinguished).
- (4) Set digitizing oscilloscope channel 3 and trigger probe attenuation to 10.
- (5) Setup digitizing oscilloscope to measure pulse width.
- (6) Verify that the digitizing oscilloscope indicates within the limits listed in table 12 for the **Per** and **Wid** setting.
- (7) Set TI to the next **Per** and **Wid** settings listed in table 12.
- (8) Repeat (5) through (7) above.
- (9) Repeat (8) above for the remaining **Per** and **Wid** settings listed in table 12.



Table 12. 9211 Pulse Width

Test instrument settings		Digitizing oscilloscope indications (sec)	
Per setting	Wid setting	Min	Max
10 nsec	1.6 nsec	1.29e-9	1.91e-9
10 nsec	5 nsec	4.675e-9	5.25e-9
20 nsec	10 nsec	9.62e-9	10.38e-9
200 nsec	100 nsec	99.2e-9	100.8e-9
1 μsec	500 nsec	497.2e-9	502.8e-9
4 μsec	2 μsec	1.99e-6	2.01e-6
20 μsec	10 μsec	9.95e-6	10.05e-6
200 μsec	100 μsec	99.5e-6	100.5e-6
2 msec	1 msec	0.995e-3	1.005e-3
20 msec	10 msec	9.95e-3	10.05e-3
200 msec	100 msec	99.5e-3	100.5e-3

- (10) Press **DISABLE** pushbutton (model 9211 output module) to off ( red light lit).
- (11) Disconnect cable from TI 9211 module **OUTPUT**.
- (12) Connect cable to TI 9215 module **OUTPUT**.
- (13) Press TI pushbuttons as listed in (a) through (h) below:
  - (a) **CHANNEL B**.
  - (b) **Vhigh** and enter **4** from data keyboard and press **ENTER/HZ**.
  - (c) **Vlow** and enter **0** from the data keyboard and press **ENTER/HZ**.
  - (d) **Lead** and enter **5** from data keyboard and press **n/GHz**.
  - (e) **Trail** and enter **5** from data keyboard and press **n/GHz**.
  - (f) **Per** and enter **20** from data keyboard and press **n/GHz**.
  - (g) **Wid** and enter **10** from data keyboard and press **n/GHz**.
  - (h) Press, **DISABLE** pushbutton (model 9215 output module) to on (red light extinguished).
- (14) Set digitizing oscilloscope channel 3 and trigger probe attenuation to 10.
- (15) Setup digitizing oscilloscope to measure pulse width.
- (16) Verify that the digitizing oscilloscope indicates within the limits listed in table 13 for the **Per** and **Wid** setting.
- (17) Set TI to the next **Per** and **Wid** settings listed in table 13.
- (18) Repeat (15) through (17) above.
- (19) Repeat (18) above for the remaining **Per** and **Wid** settings listed in table 13.

Table 13. 9215 Pulse Width

Test instrument settings				Digitizing oscilloscope indications (sec)	
Per setting		Wid setting		Min	Max
20	nsec	10	nsec	9.62e-9	10.38e-9
200	nsec	100	nsec	99.25e-9	100.8e-9
1	µsec	500	nsec	497.2e-9	502.8e-9
4	µsec	2	µsec	1.99e-6	2.01e-6
20	µsec	10	µsec	9.95e-6	10.05e-6
200	µsec	100	µsec	99.5e-6	100.5e-6
2	msec	1	msec	.995e-3	1.005e-3
20	msec	10	msec	9.95e-3	10.05e-3
200	msec	100	msec	99.5e-3	100.5e-3

(20) Press **DISABLE** pushbutton (model 9215 output module) to off ( red light lit).

(21) Disconnect cable from TI 9215 module **OUTPUT**.

**b. Adjustments.** No adjustments can be made.

## 12. Pulse Jitter

### a. Performance Check

- (1) Connect equipment as shown in figure 3.
- (2) Reset digitizing oscilloscope and cal the gain.
- (3) Press TI pushbuttons as listed in (a) through (f) below:
  - (a) **CHANNEL A**.
  - (b) **Vhigh** and enter **5** from data keyboard and press **ENTER/HZ**.
  - (c) **Vlow** and enter **0** from the data keyboard and press **ENTER/HZ**.
  - (d) **Lead** and enter **.9** from data keyboard and press **n/GHz**.
  - (e) **Trail** and enter **.9** from data keyboard and press **n/GHz**.
  - (f) **Per** and enter **20** from data keyboard and press **n/GHz**.
  - (g) **Wid** and enter **10** from data keyboard and press **n/GHz**.
  - (h) Press **DISABLE** pushbutton (model 9211 output module) to on (red light extinguished).
- (4) Set digitizing oscilloscope channel 3 and trigger probe attenuation to 10.
- (5) Setup digitizing oscilloscope to display the leading edge of a single pulse at the center of the display.
- (6) Setup digitizing oscilloscope to take a time histogram with 300 samples at the mid point of the leading edge of the displayed pulse.
- (7) Verify that the digitizing oscilloscope sigma indication is less than the limit listed in table 14.

Table 14. 9211 Pulse Jitter

Digitized oscilloscope indication (psec)
<60 psec

- (8) Press **DISABLE** pushbutton (model 9211 output module) to off ( red light lit).
- (9) Disconnect cable from TI 9211 module **OUTPUT**.
- (10) Connect cable to TI 9215 module **OUTPUT**.
- (11) Press TI pushbuttons as listed in (a) through (h) below:
  - (a) **CHANNEL B**.
  - (b) **Vhigh** and enter **5** from data keyboard and press **ENTER/HZ**.
  - (c) **Vlow** and enter **0** from the data keyboard and press **ENTER/HZ**.
  - (d) **Lead** and enter **5** from data keyboard and press **n/GHz**.
  - (e) **Trail** and enter **5** from data keyboard and press **n/GHz**.
  - (f) **Per** and enter **20** from data keyboard and press **n/GHz**.
  - (g) **Wid** and enter **10** from data keyboard and press **n/GHz**.
  - (h) Press **DISABLE** pushbutton (model 9215 output module) to on (red light extinguished).
- (12) Setup digitizing oscilloscope to display the leading edge of a single pulse at the center of the display.
- (13) Setup digitizing oscilloscope to take a time histogram with 300 samples at the mid point of the leading edge of the displayed pulse.
- (14) Verify that the digitizing oscilloscope sigma indication is less than the limit listed in table 15.

Table 15. 9215 Pulse Jitter

Digitized oscilloscope indication (psec)
<60 psec

- (15) Press **DISABLE** pushbutton (model 9215 output module) to off ( red light lit).
  - (16) Disconnect cable from TI 9215 module **OUTPUT**.
- b. Adjustments.** No adjustments can be made.

### 13. Delay

#### a. Performance Check

- (1) Connect equipment as shown in figure 3.
- (2) Reset digitizing oscilloscope and cal the gain.
- (3) Press TI pushbuttons as listed in (a) through (h) below:

- (a) **CHANNEL A.**
  - (b) **Vhigh** and enter **2.5** from data keyboard and press **ENTER/HZ.**
  - (c) **Vlow** and enter **0** from the data keyboard and press **ENTER/HZ.**
  - (d) **Lead** and enter **.9** from data keyboard and press **n/GHz.**
  - (e) **Trail** and enter **.9** from data keyboard and press **n/GHz.**
  - (f) **Per** and enter **20** from data keyboard and press **n/GHz.**
  - (g) **Wid** and enter **17** from data keyboard and press **n/GHz.**
  - (h) Press **DISABLE** pushbutton (model 9211 output module) to on (red light extinguished).
- (4) Setup digitizing oscilloscope to display the pulse train.
- (5) Setup digitizing oscilloscope to perform a  $\Delta t$  measurement by placing V marker 1, V marker 2, Start Marker and Stop Marker at the same point of the leading edge of the left most pulse that is displayed on the crt.
- (6) Press TI pushbuttons as listed in (a) and (b) below:
- (a) **CHANNEL A.**
  - (b) **Delay** and enter **10** from data keyboard and press **n/GHz.**
- (7) Set digitizing oscilloscope Stop marker on the leading edge of the displayed pulse where the V markers intersect the pulse.
- (8) Verify that the digitizing oscilloscope  $\Delta T$  indication is within the limits listed in table 16 for the **Delay** setting.
- (9) Set TI to the next **Per** and **Wid** settings listed in table 16.
- (10) On the digitizing oscilloscope turn off the V markers and the Start and Stop markers.
- (11) Repeat (4) and (5) above.
- (12) Press TI pushbuttons as listed in (a) and (b) below:
- (a) **Channel A.**
  - (b) **Delay** and enter the next delay value in table 16 from the data keyboard.
- (13) Repeat (7) and (8) above.
- (14) Repeat (9) through (13) above for the remaining **Per**, **Wid** and **Delay** settings listed in table 16.

Table 16. 9211 Delay

Test instrument settings			Digitizing oscilloscope settings		Digitizing oscilloscope $\Delta T$ indications (sec)	
<b>Per</b>	<b>Wid</b>	<b>Delay</b>	Time range	Time delay	Min	Max
20 n	17 n	10 n	20e-9	30e-9	8.95e-9	11.05e-9
200 n	175 n	100 n	200e-9	190e-9	98.5e-9	101.5e-9
2 $\mu$	1.75 $\mu$	1 $\mu$	2e-6	1.8e-6	0.994e-6	1.006e-6
20 $\mu$	17.5 $\mu$	10 $\mu$	20e-6	18e-6	9.949e-6	10.051e-6
200 $\mu$	175 $\mu$	100 $\mu$	200e-6	180e-6	99.5e-6	100.5e-6

Table 16. 9211 Delay - Continued

Test instrument settings			Digitizing oscilloscope settings		Digitizing oscilloscope $\Delta T$ indications (sec)	
Per	Wid	Delay	Time range	Time delay	Min	Max
2 m	1.75 m	1 m	2e-3	1.8e-3	0.995e-3	1.005e-3
20 m	17.5 m	10 m	20e-3	18e-3	9.95e-3	10.05e-3
200 m	175 m	100 m	200e-3	180e-3	99.5e-3	100.5e-3

- (15) Press **DISABLE** pushbutton (model 9211 output module) to off (red light lit).
- (16) Disconnect cable from TI 9211 module **OUTPUT**.
- (17) Connect cable to TI 9215 module **OUTPUT**.
- (18) Press TI pushbuttons as listed in (a) through (h) below:
- CHANNEL B**.
  - Vhigh** and enter **5** from data keyboard and press **ENTER/HZ**.
  - Vlow** and enter **0** from the data keyboard and press **ENTER/HZ**.
  - Lead** and enter **5** from data keyboard and press **n/GHz**.
  - Trail** and enter **5** from data keyboard and press **n/GHz**.
  - Per** and enter **40** from data keyboard and press **n/GHz**.
  - Wid** and enter **10** from data keyboard and press **n/GHz**.
  - Press **DISABLE** pushbutton (model 9215 output module) to on (red light extinguished).
- (19) Setup digitizing oscilloscope to display the pulse train.
- (20) Setup digitizing oscilloscope to perform a  $\Delta T$  measurement by placing V marker 1, V marker 2, Start Marker and Stop Marker at the same point of the leading edge of the left most pulse that is displayed on the crt.
- (21) Press TI pushbuttons as listed in (a) and (b) below:
- CHANNEL B**.
  - Delay** and enter **10** from data keyboard and press **n/GHz**.
- (22) Set digitizing oscilloscope Stop marker on the leading edge of the displayed pulse where the V markers intersect the pulse.
- (23) Verify that the digitizing oscilloscope  $\Delta T$  indication is within the limits listed in table 17 for the **Delay** setting.
- (24) Set TI to the next **Per** and **Wid** settings listed in table 17.
- (25) On the digitizing oscilloscope turn off the V markers and the Start and Stop markers.
- (26) Repeat (22) and (23) above.
- (27) Press TI pushbuttons as listed in (a) and (b) below:
- CHANNEL B**.
  - Delay** and enter the next delay value in table 17 from the data keyboard.

(28) Repeat (23) and (24) above.

(29) Repeat (24) through (28) above for the remaining **Per**, **Wid** and **Delay** settings listed in table 17.

Table 17. 9215 Delay

Test instrument settings			Digitizing oscilloscope settings		Digitizing oscilloscope $\Delta T$ indications (sec)	
Per	Wid	Delay	Time range	Time delay	Min	Max
40 n	10 n	10 n	50e-9	16e-9	8.95e-9	11.05e-9
200 n	175 n	100 n	200e-9	190e-9	98.5e-9	101.5e-9
2 $\mu$	1.75 $\mu$	1 $\mu$	2e-6	1.8e-6	0.994e-6	1.006e-6
20 $\mu$	17.5 $\mu$	10 $\mu$	20e-6	18e-6	9.949e-6	10.051e-6
200 $\mu$	175 $\mu$	100 $\mu$	200e-6	180e-6	99.5e-6	100.5e-6
2 m	1.75 m	1 m	2e-3	1.8e-3	0.995e-3	1.005e-3
20 m	17.5 m	10 m	20e-3	18e-3	9.95e-3	10.05e-3
200 m	175 m	100 m	200e-3	180e-3	99.5e-3	100.5e-3

(30) Press **DISABLE** pushbutton (model 9215 output module) to off ( red light lit).

(31) Disconnect cable from TI 9215 module **OUTPUT**.

**b. Adjustments.** No adjustments can be made.

#### 14. Trigger Level and Polarity

##### a. Performance Check

(1) Connect equipment as shown in figure 4 below.

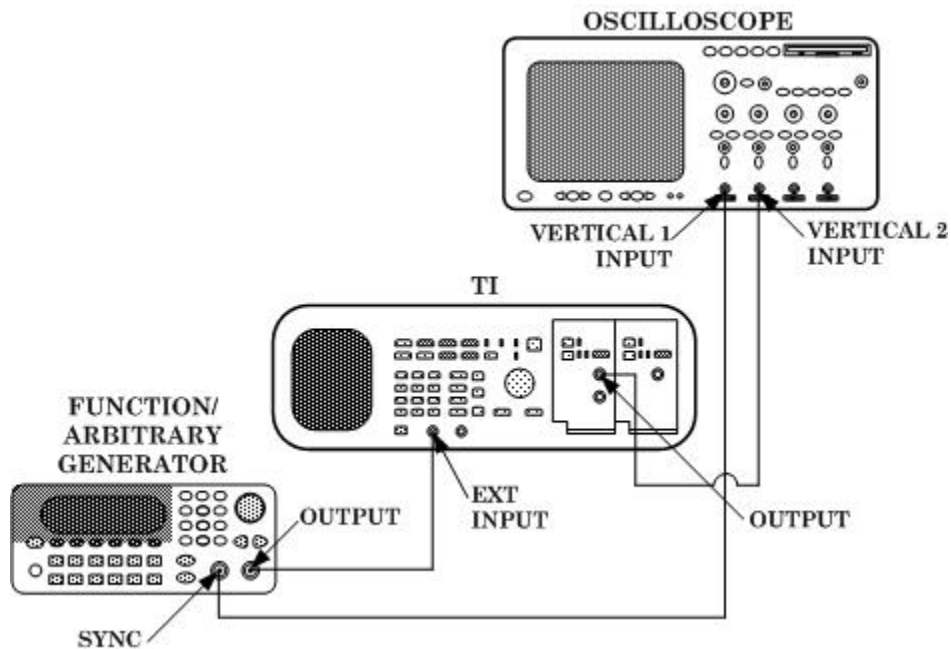

Figure 4. Trigger level and polarity.

- (2) Press TI pushbuttons as listed in (a) through (l) below:
  - (a) **CHANNEL A.**
  - (b) **Vhigh** and enter **1.0** from data keyboard and press **ENTER/HZ.**
  - (c) **Vlow** and enter **0** from the data keyboard and press **ENTER/HZ.**
  - (d) **Lead** and enter **.9** from data keyboard and press **n/GHz.**
  - (e) **Trail** and enter **.9** from data keyboard and press **n/GHz.**
  - (f) **Per** and enter **100** from data keyboard and press **n/GHz.**
  - (g) **Wid** and enter **1** from data keyboard and press **μ/MHz.**
  - (h) **Trigger Impedance 50.**
  - (i) **Trigger Level 0.5.**
  - (j) **Trigger Slope positive.**
  - (k) **Trigger Mode single.**
  - (l) **DISABLE** (model 9211 output module) to on (red light extinguished).
- (3) Set up function/arbitrary generator for an output of 1.00 Vpp 100 kHz square wave.
- (4) Set oscilloscope **Vertical 1** and **Vertical 2** input impedance to 50 Ω.
- (5) Adjust oscilloscope controls to obtain a satisfactory dual two-channel display on the crt.
- (6) Verify that the displayed traces on the oscilloscope crt go positive at the same time.
- (7) Set TI **Trigger Level** to **-0.5.**
- (8) Verify that the oscilloscope **Vertical 2** trace still displays a pulse.
- (9) Set TI **Trigger Level** to **-0.52.**
- (10) Verify that the oscilloscope **Vertical 2** trace does not display a pulse.
- (11) Set TI **Trigger Level** to **0.52.**
- (12) Verify that the oscilloscope **Vertical 2** trace does not display a pulse.
- (13) Set TI **Trigger Level** to **0.5** and **Trigger Slope** to **Neg.**
- (14) Verify that the **Vertical 2** trace goes positive at the same time that the **Vertical 1** trace goes negative.
- (15) Disconnect all equipment from the TI.

#### **b. Adjustments**

- (1) Press TI **POWER ON/DISABLE** key to **DISABLE.**
- (2) Disconnect 115 V power cord from TI.
- (3) Remove TI top cover.
- (4) Remove power supply module from TI chassis, leaving the power supply connected to the TI motherboard.

- (5) Reconnect 115 V power cord to TI .
- (6) Press TI **POWER ON/DISABLE** key to **ON**.
- (7) Press TI pushbuttons as listed in (a) through (l) below:
  - (a) **CHANNEL A**.
  - (b) **Vhigh** and enter **1.0** from data keyboard and press **ENTER/HZ**.
  - (c) **Vlow** and enter **0** from the data keyboard and press **ENTER/HZ**.
  - (d) **Lead** and enter **.9** from data keyboard and press **n/GHz**.
  - (e) **Trail** and enter **.9** from data keyboard and press **n/GHz**.
  - (f) **Per** and enter **100** from data keyboard and press **n/GHz**.
  - (g) **Wid** and enter **1** from data keyboard and press **μ/MHz**.
  - (h) **Trigger Impedance 50**.
  - (i) **Trigger Level 0.1**.
  - (j) **Trigger Slope positive**.
  - (k) **Trigger Mode single**.
  - (l) Press **DISABLE** pushbutton (model 9211 output module) to on (red light extinguished).
- (8) Set up function/arbitrary generator for an output of 1.00 Vpp 100 kHz square wave.
- (9) Set oscilloscope **Vertical 1** and **Vertical 2** input impedance to 50 Ω.
- (10) Adjust oscilloscope controls to obtain a satisfactory dual two-channel display on the crt.
- (11) Rotate TI **FINE CONTROL KNOB** clockwise, increasing the trigger level. Record the level at which the waveform disappears. Reset the trigger level to 0.10 V.
- (12) Rotate TI **FINE CONTROL KNOB** counterclockwise, decreasing the trigger level. Record the level at which the waveform disappears. Reset trigger level to 0.10 V.
- (13) Add the results of (11) and (12) above. Divide this value by two and subtract the result from the value recorded in step (11). Rotate TI **FINE CONTROL KNOB** to adjust trigger level to this new value.
- (14) Adjust R66 (fig. 5) until **Vertical 2** waveform just disappears (R).
- (15) Using TI **FINE CONTROL KNOB** adjust trigger level to 0.52 V.
- (16) Adjust C11 (fig. 5) to the point that the waveform just disappears (R).
- (17) Press TI **POWER ON/DISABLE** key to **DISABLE**.
- (18) Disconnect 115 V power cord from TI.
- (19) Reinstall power supply module in TI chassis.
- (20) Replace TI top cover.
- (21) Reconnect 115 V power cord to TI .
- (22) Press TI **POWER ON/DISABLE** key to **ON**.



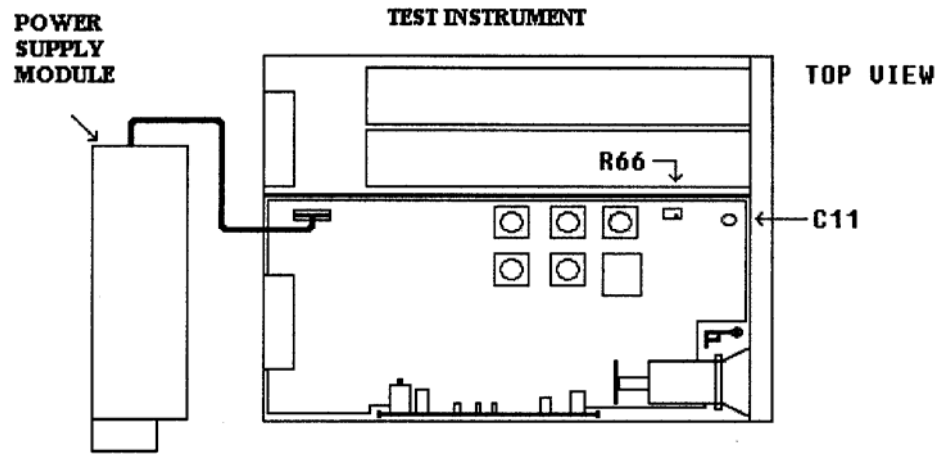

Figure 5. Trigger level adjust.

## 15. Double Pulse

### a. Performance Check

- (1) Connect equipment as shown in figure 4 .
- (2) Press TI pushbuttons as listed in (a) through (m) below:
  - (a) **CHANNEL A.**
  - (b) **Vhigh** and enter **1.0** from data keyboard and press **ENTER/HZ.**
  - (c) **Vlow** and enter **0** from the data keyboard and press **ENTER/HZ.**
  - (d) **Lead** and enter **.9** from data keyboard and press **n/GHz.**
  - (e) **Trail** and enter **.9** from data keyboard and press **n/GHz.**
  - (f) **Per** and enter **300** from data keyboard and press **n/GHz.**
  - (g) **Wid** and enter **100** from data keyboard and press **n/GHz.**
  - (h) **Double Off**
  - (i) **Trigger Impedance 50.**
  - (j) **Trigger Level 0.1.**
  - (k) **Trigger Slope positive.**
  - (l) **Trigger Mode single.**
  - (m) Press **DISABLE** pushbutton (model 9211 output module) to on (red light extinguished).
- (3) Set up function/arbitrary generator for an output of 1.02 Vpp 1.5 MHz square wave.
- (4) Set oscilloscope **Vertical 1** and **Vertical 2** input impedance to 50 Ω.
- (5) Adjust oscilloscope controls to obtain a satisfactory dual two-channel display on the crt.
- (6) Verify for each positive pulse displayed on **Vertical 1** of the oscilloscope that there is one positive pulse displayed on **Vertical 2**.

(7) Press TI pushbuttons as listed in (a) and (b) below:

(a) **Delay** and enter **200** from data keyboard and press **N/GHz**.

(b) **2 pulse On**.

(8) Verify for each positive pulse displayed on **Vertical 1** of the oscilloscope that there are two positive pulses displayed on **Vertical 2**.

(9) Disconnect all equipment from the TI.

**b. Adjustments.** No adjustments can be made.

## **16. Final Procedure**

**a.** Deenergize and disconnect all equipment.

**b.** Annotate and affix DA label/form in accordance with TB 750-25

By Order of the Secretary of the Army:

**ERIC K. SHINSEKI**  
*General, United States Army*  
*Chief of Staff*

**OFFICIAL:**

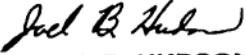
  
**JOEL B. HUDSON**  
*Administrative Assistant to the*  
*Secretary of the Army*

0224711

Distribution:

To be distributed in accordance with initial distribution number (IDN) 344748, requirements for calibration procedure TB 9-6625-2332-50.



**THESE ARE THE INSTRUCTIONS FOR SENDING AN ELECTRONIC 2028**

The following format must be used if submitting an electronic 2028. The subject line must be exactly the same and all fields must be included; however, only the following fields are mandatory: 1, 3, 4, 5, 6, 7, 8, 9, 10, 13, 15, 16, 17, and 27.

From: "Whomever" [whomever@avma27.army.mil](mailto:whomever@avma27.army.mil)

To: [2028@redstone.army.mil](mailto:2028@redstone.army.mil)

Subject: DA Form 2028

1. **From:** Joe Smith
2. **Unit:** Home
3. **Address:** 4300 Park
4. **City:** Hometown
5. **St:** MO
6. **Zip:** 77777
7. **Date Sent:** 19-Oct-93
8. **Pub No:** TB 9-6625-xxxx-35
9. **Pub Title:** Calibration Procedure for ...
10. **Publication Date:**
11. **Change Number:**
12. **Submitted Rank:** MSG
13. **Submitter Fname:** Joe
14. **Submitter Mname:** T
15. **Submitter Lname:** Smith
16. **Submitter Phone:** (123) 123-1234
17. **Problem:** 1
18. **Page:** 2
19. **Paragraph:** 3
20. **Line:** 4
21. **NSN:** 5
22. **Reference:** 6
23. **Figure :** 7
24. **Table:** 8
25. **Item:** 9
26. **Total:** 123
27. **Text:**

This is the text for the problem below line 27.

